



FRENI PNEUMATICI A PINZA
PNEUMATIC CALIPER BRAKES





made in Italy

Per controllare la decelerazione di parti in movimento per piccole e medie potenze il sistema più semplice è la combinazione di un disco freno con una o più pinze a comando pneumatico. Le pinze vengono azionate da un pistone a membrana che deve essere posizionato lontano da fonti di calore, esse sono autoallineanti ed il consumo del ferodo viene ripreso automaticamente. I dischi sono disponibili in ghisa da 200 a 600 mm, e possono essere anche realizzati in conformità alle esigenze del cliente. Le pinze freno RE sono progettate e realizzate per poter operare secondo le condizioni di lavoro e le caratteristiche tecniche definite nel presente catalogo. Esse coprono una vasta gamma di applicazioni, in grado di soddisfare tutte le esigenze della clientela. È opportuno quindi selezionare la tipologia di prodotto più adatta alle proprie occorrenze, facendo riferimento ai parametri delle relative specifiche tecniche.

Scelta dell'applicazione In fase di progettazione è opportuno selezionare la pinza freno da impiegare in modo da avere una corretta applicazione della stessa, e poter quindi sfruttare al meglio le caratteristiche di ogni tipologia di prodotto disponibile. Si ricorda inoltre che, per ottenere il valore nominale della coppia, occorre avere un completo assestamento del materiale sul disco. Per ciò che riguarda in particolare le pinze freno usate come stazionamento è consigliabile un calcolo non inferiore a F.S.2.

Suggerimenti per un corretto utilizzo del prodotto Per prevenire spiacevoli incidenti si invitano gli addetti al rispetto della direttiva CEE 89/656 e 89/686 relativa all'impiego di dispositivi ed equipaggiamenti idonei per la protezione adeguata dei carichi e/o pesi. Inoltre si ricorda che:

- le pinze freno negative contengono molle meccanicamente precaricate, il cui montaggio e manutenzione deve essere eseguita da personale specializzato,
- le pinze freno idrauliche richiedono l'utilizzo di olio a base minerale SAE ISO 46 in quantità estremamente limitate per il rispetto dell'ambiente.

Rispetto delle normative Il materiale d'attrito impiegato nei freni a pinza è esente da amianto. Si raccomanda il suo corretto smaltimento, una volta usurato, secondo le leggi vigenti nel Paese in cui vengono utilizzati (direttiva CEE 75/442). Per l'eliminazione e il recupero degli oli usati il riferimento è alla direttiva CEE 75/439. Questa parte di macchina è destinata ad essere incorporata nella macchina per la quale è stata progettata e non può funzionare in modo indipendente. Si fa divieto di messa in servizio prima di aver dichiarato conforme alle disposizioni vigenti la macchina di destinazione.

FRENI PNEUMATICI A PINZA PNEUMATIC CALIPER BRAKES

To control the deceleration of moving parts for small and medium powers, the best solutions is the combination of a brake disc with one or more pneumatic calipers. The calipers are actuated by a rubber diaphragm piston - that should be placed away from any heat source, are self aligning, and do not require adjustments for wear. The discs are available in diameters from 200-600 mm, and can also be made to the customers' specific designs. RE caliper brakes are planed and realized to operate according to the work conditions and the technical features which are mentioned in this catalogue. They cover a wide range of applications in order to satisfy all the customers' needs. We advise you to choose the type of product that better suits your needs and also to refer to the parameters of the respective and specific technics.

Choice of the application *In planning we suggest you to choose the caliper brake you use in order to have its correct application. In this way you can take the greatest advantage from the features of every type of available products. Moreover we remind you that you need to have a total arrangement of the material on the disk in order to get the nominal value of the torque.*

As far as the caliper brakes used as stop are concerned we advise you a calculation not lower than F.S.2.

Suggestions for a correct use of the product *The staff is advise to respect the E.U. directives 89/656 and 89/686 in order to avoid unpleasant incidents. They concern the use of suitable devices and equipments to be properly protected against loads and/or weights. Moreover we remind you that:*

- *the hydraulically released caliper brakes contain mechanically pre-loaded springs whose assemblage and maintenance must be carried out by qualified staff,*
- *the hydraulic caliper brakes require the use of oil on mineral base SAE ISO 46 in extremely limited quantity in order to respect the environment.*

Respect of the laws *The attrition material used in the caliper brakes is free from asbetos. We suggest you to get rid of it correctly once it is worn out according to the current laws of the country where it is used (E.U. directive 75/442). As far as the elimination and recycling of the used oil are concerned we remind you to refer to the E.U. directive 75/439. This product is intended to be used on the machine it has been designed for and it must not be used independently. It is forbidden to use it to machines that are not in compliance with the current regulation.*

**SIMBOLI
E UNITÀ DI MISURA**
**SYMBOLS
AND UNIT OF MEASUREMENT**
Cd = Coppia dinamica [Nm]

Cd = *Dynamic torque [Nm]*
J = Inerzia [kg·m²]

J = *Total inertia load [kg·m²]*
n = Numero di giri [rpm]

n = *Rotating speed [min]*
t = Tempo di frenatura [s]

t = *Time [s]*
v = Velocità lineare [m/min]

v = *Web speed [m/min]*
z = Numero interventi al minuto

z = *Stops/minute*
T = Tensione sul materiale [N]

T = *Web tension [N]*
D = Diametro bobina [m]

D = *Roll diameter [m]*
Pc = Potenza dissipata in calore in continuo [kW]

Pc = *Continuous mean power [kW]*
Pz = Potenza dissipata in calore per ogni frenata [kW]

Pz = *Mean braking power [kW]*
m = Peso massimo bobina [kg]

m = *Coil maximum weight [kg]*
r = Raggio massimo bobina [m]

r = *Coil maximum radius [m]*
d = Diametro disco [m]

d = *Disc diameter [m]*
Rm = Raggio medio disco [m]

Rm = *Medium disc radius [m]*
F = Forza di spinta tangenziale [N]

F = *Tangential force [N]*
Mp = Mezzeria pastiglia [m]

Mp = *Center pad [m]*

GUIDA ALLA SCELTA DELLA PINZA

GUIDE FOR CALIPER SELECTION

FORMULE UTILI

USEFUL FORMULAS

$J = \frac{m \cdot r^2}{2} = \mathbf{kgm^2}$	Inerzia bobina <i>Roll inertia</i>
$n = \frac{v}{\pi \cdot D} = \mathbf{rpm}$	Numero di giri <i>Revolutions per minute</i>
$v = \pi \cdot D \cdot n = \mathbf{m/min}$	Velocità lineare <i>Web speed</i>

Per poter calcolare la coppia dinamica C_d identifichiamo tre applicazioni basilari di cui forniamo le relative basi di calcolo.

To calculate the Dynamic torque (C_d) we identify three fundamental applications. Below you can find the necessary formulas for the calculation.

FRENATURA CICLICA

CYCLIC STOP

$C_d = \frac{J \cdot n}{9,55 \cdot t} = \mathbf{Nm}$	Coppia dinamica <i>Dynamic torque</i>
$P_z = \frac{J \cdot n^{1/4}}{182,5 \cdot 10^{3/4} \cdot t} = \mathbf{kW}$	Potenza dissipata in calore per ogni frenata <i>Mean breaking power</i>
$P_c = \frac{P \cdot z \cdot z \cdot t}{60} = \mathbf{kW}$	Potenza dissipata in calore in continuo <i>Continuous mean power</i>

SLITTAMENTO CONTINUO

TENSIONING

$P_c = \frac{T \cdot v}{60 \cdot 10^{3/4}} = \mathbf{kW}$	Potenza dissipata in calore in continuo <i>Continuous mean power</i>
$C_d = \frac{T \cdot v}{z} = \mathbf{Nm}$	Coppia dinamica <i>Dynamic torque</i>

FRENATURA D'EMERGENZA

EMERGENCY STOP

$C_d = \frac{m \cdot D \cdot v}{240 \cdot t} = \mathbf{Nm}$	Coppia dinamica <i>Dynamic torque</i>
$P_z = \frac{J \cdot n^{1/4}}{182,4 \cdot 10^{3/4} \cdot t} = \mathbf{kW}$	Potenza dissipata in calore per frenata <i>Mean breaking power</i>



PINZE PNEUMATICHE POSITIVE CX
Positive/negative
CX PNEUMATIC CALIPERS
Air applied/spring applied

Le pinze Combiflex sono utilizzate nelle applicazioni che necessitano di frenature per piccole e medie potenze, o frenature di emergenza. La peculiarità del sistema è la modularità: una o più pinze possono essere installate su dischi di diverse dimensioni, ottenendo il sistema ideale per ogni esigenza.

Inoltre, la possibilità di attivare o disattivare ogni pinza in funzione della coppia richiesta, offre la massima flessibilità nell'uso di materiali differenti.

Le stesse pinze sono disponibili in versione negativa per frenature di emergenza (4,5 bar o 6 bar).

Combiflex calipers are particularly adapted for applications with low or medium braking force or for emergency-brakes.

The special characteristic of this system is its modular conception: one or more calipers can be installed on brake discs with different dimensions obtaining the perfect solution for every requirement.

Also, each caliper can be activated or deactivated on the basis of the required torque, giving maximum flexibility when using different kind of materials.

The same calipers are available in the spring-applied version (4,5 bar or 6 bar) for emergency stop.



Versione in miniatura della pinza CX, la pinza CX NANO è la nuova soluzione per le applicazioni dove sono necessarie coppie di frenatura significative in spazi molto ridotti. È disponibile per dischi di diversi spessori da 6, 8 e 12,5 mm, semplicemente andando a selezionare in fase d'ordine la staffa di fissaggio corretta.

CX-NANO pneumatic caliper, which is the miniature of the CX caliper, is the new solution for applications where considerable braking torques in reduced spaces are needed. It is available for different thickness discs: 6, 8 or 12,5 mm; simply selecting, during the order, the right bracket.

Ridotte Reduced torque

Le pinze Combiflex ridotte sono ideate per le applicazioni che necessitano di una maggiore sensibilità nella frenatura, dove la coppia richiesta è quindi molto bassa. Ideali per l'uso con materiali molto leggeri quali TNT, carta leggera, film plastico o con materiali di fascia stretta.

Sono disponibili tre tipi di pinze ridotte con differente capacità di frenatura: 10%, 16% e 40%. Il valore in percentuale indica la capacità di frenatura rispetto alla pinza standard.

The Combiflex calipers with reduced torque have been designed for applications which require highest sensibility in terms of braking, where the required torque is very low. These calipers are adapted for very light materials as TNT, thin paper, plastic film or for narrow cut material.

We manufacture three different types of reduced torque calipers with different braking forces: 10%, 16% and 40%. The percentage value indicates the braking force in comparison with the standard caliper.



pinza CX ridotta 10%
CX caliper reduced torque 10%

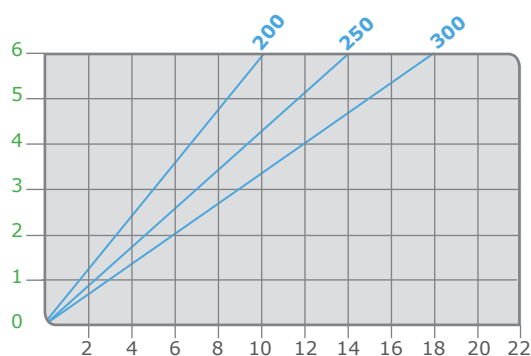

F= 153 N forza di spinta a 6 bar / *tangential force at 6 bar*



pinza CX ridotta 16%
CX caliper reduced torque 16%

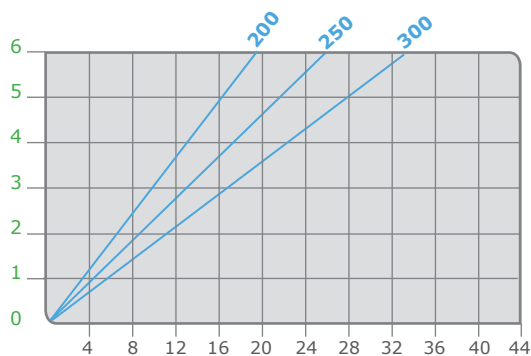

F= 286 N forza di spinta a 6 bar / *tangential force at 6 bar*



pinza CX ridotta 40%
CX caliper reduced torque 40%

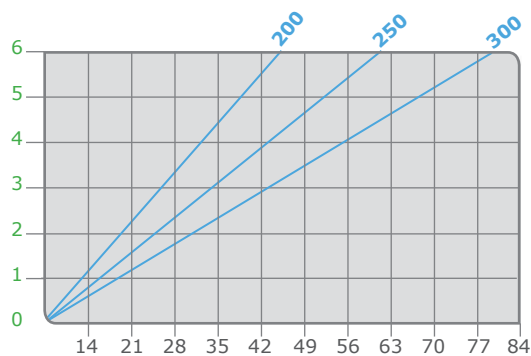

F= 675 N forza di spinta a 6 bar / *tangential force at 6 bar*

PINZA PNEUMATICA CX NANO
Positiva
CX NANO PNEUMATIC CALIPERS
Air applied

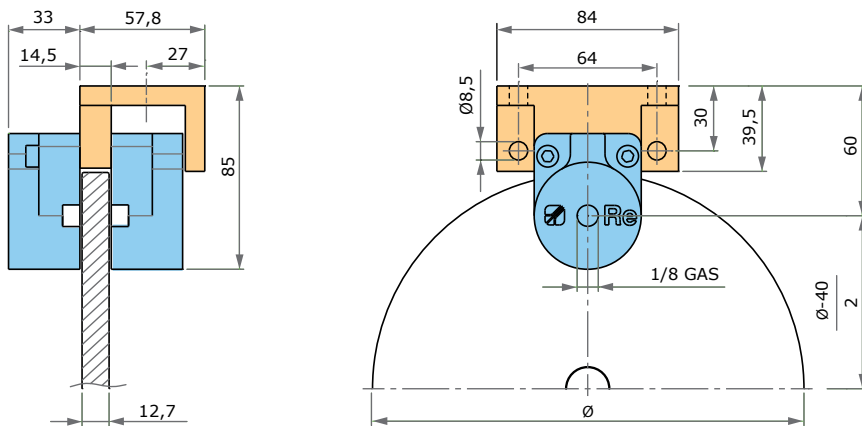

CX nano
pinza pneumatica positiva
pneumatic caliper brake
air applied

Forza di spinta (F) / *tangential force (F)*
510 N a 6 bar / *at 6 bar*

Pressione massima / *Max pressure*
6 bar

Mezzeria pastiglia (Mp) / *pad center (Mp)*
0,04 m

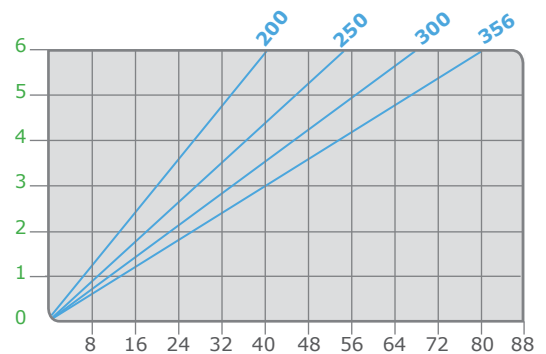

■ Diametro del disco (mm) / *Disc diameter (mm)*

■ Pressione alimentazione (bar) / *Air pressure (bar)*

■ Coppia frenante in fase di slittamento continuo (Nm)
Braking torque in tensioning (Nm)

PINZA PNEUMATICA CX positiva CX PNEUMATIC CALIPER BRAKE air applied

Pinza standard
Standard caliper

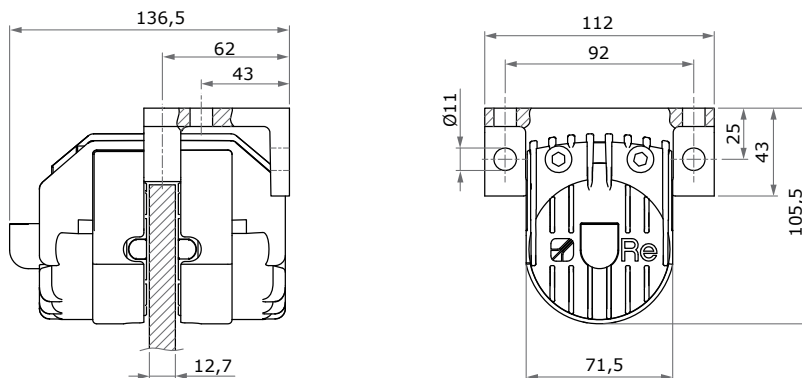

Applicazione con calettatore
Taper lock application

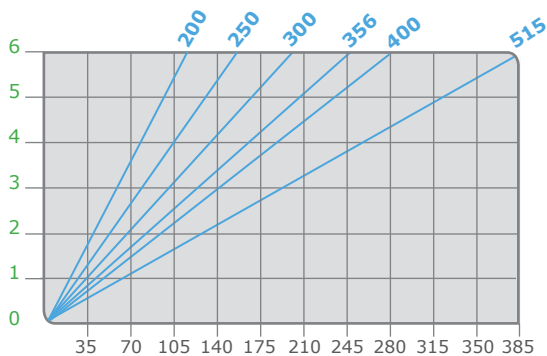
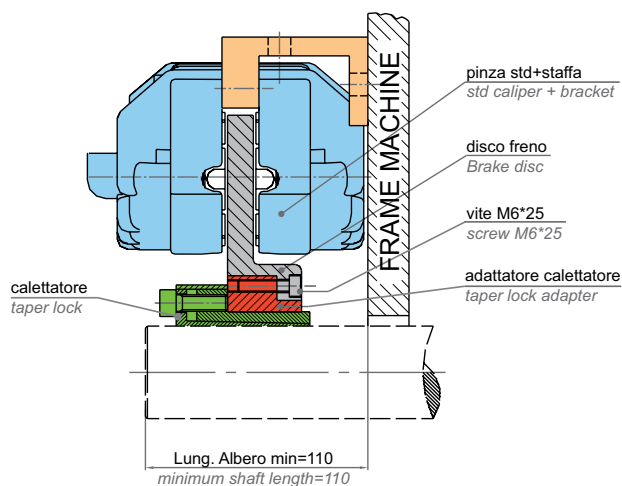

CX standard pinza pneumatica positiva pneumatic caliper brake air applied

Forza di spinta (F) / tangential force (F)
max **1682 N** a 6 bar / at 6 bar

Pressione massima / Max pressure
6 bar

Mezzeria pastiglia (Mp) / pad center (Mp)
0,065 m

**SCHEMA DI MONTAGGIO
PINZE CX
positive/negative/ridotte**
**MOUNTING SCHEME
FOR CX CALIPERS
air applied/spring applied/
reduced torque**

pinza singola CX
single CX caliper

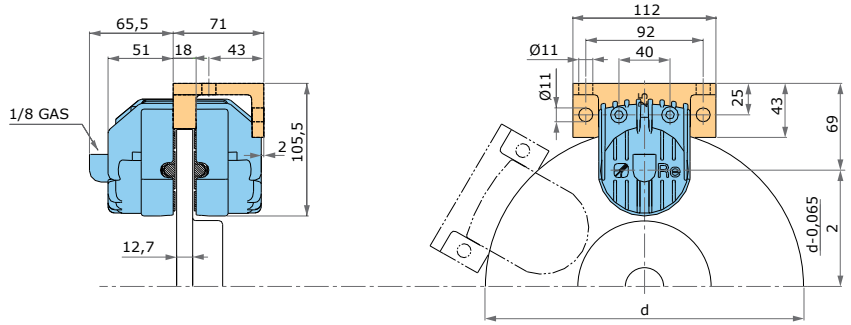

staffa per PX250
bracket for PX250

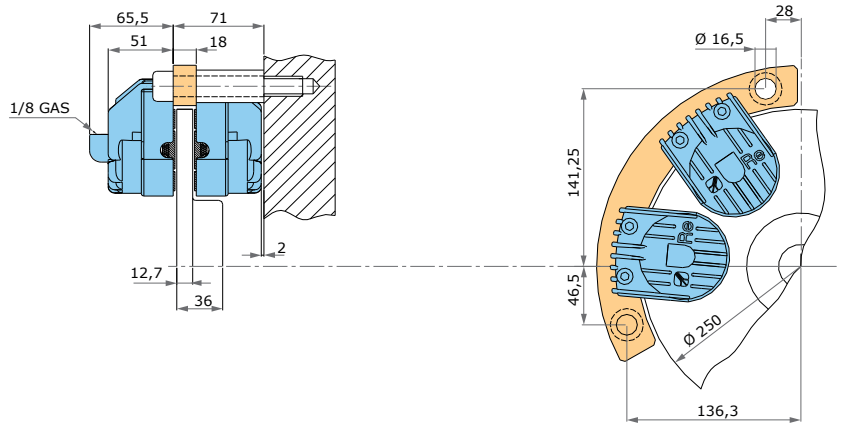

staffa per PX300
bracket for PX300

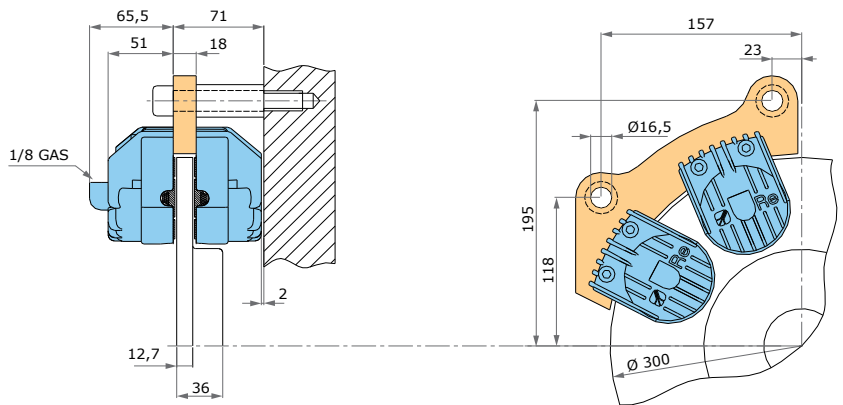

staffa per PX400
bracket for PX400

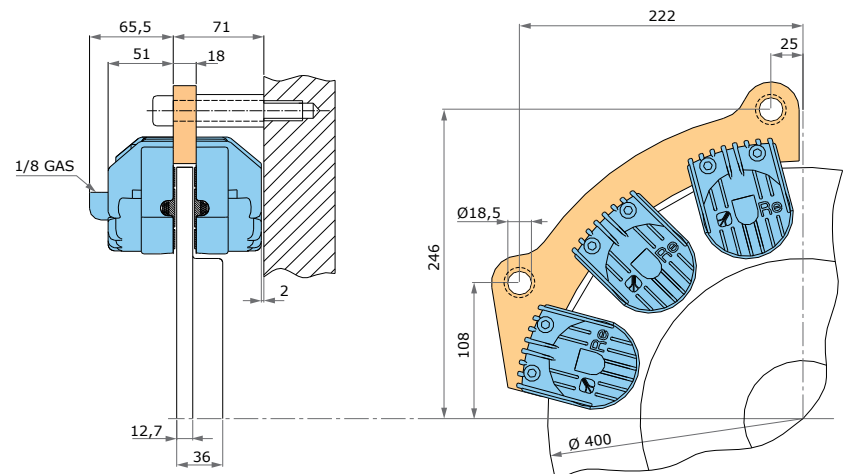

PINZE POSITIVE SA
manuali e pneumatiche
CALIPER BRAKES SA
manual and pneumatic

Le pinze SA consentono una elevata coppia di frenatura e sono quindi ideali per la frenatura di emergenza in qualsiasi tipo di macchina che lavori materiale in bobine. Le pinze vengono azionate da un pistone a membrana che deve essere posizionato lontano da fonti di calore, sono autoallineanti ed il consumo del materiale di attrito viene ripreso automaticamente.

La nostra gamma comprende modelli ad azionamento manuale o pneumatico da utilizzare in abbinamento ai nostri dischi PX. I dischi sono disponibili in ghisa da 200 a 600 mm, ma possono essere realizzati in conformità alle esigenze del cliente.

Our SA caliper brakes guarantee a very high braking torque, that makes them ideal for emergency braking in every kind of machine that handles material on reels. The calipers are set in motion by a diaphragm piston that has to be positioned far from heat sources, they are auto-aligning and the distance of the pads from the disc is automatically regulated according to the attrition.

Our product range includes manually operated and pneumatic calipers, both to be used with our PX discs. The discs are available in cast iron from 200 to 600 mm but they can also be manufactured according to the customer's special requirements.



PINZE MANUALI TIPO SA HAND OPERATED BRAKES, SA SERIES

PU/M-SA

Forza di spinta (F) / *tangential force (F)*
max 2540 N

Mezzeria pastiglia (Mp) / *pad center (Mp)*
0,025 m

Peso / *Weight*
3,3 kg

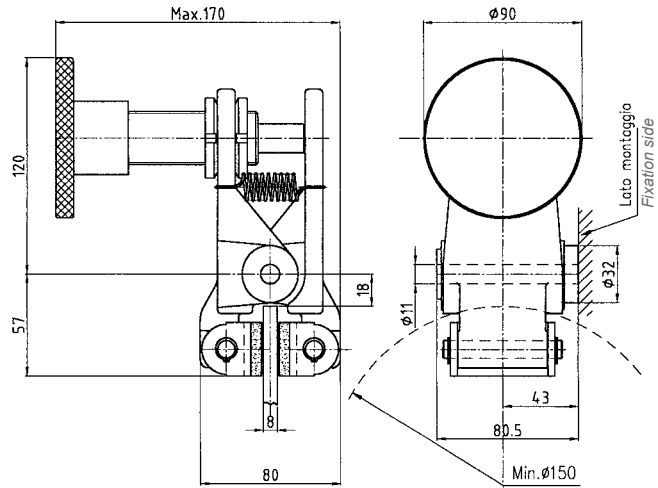
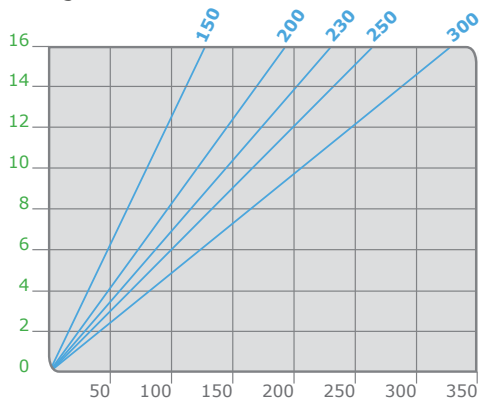

PZV/M-SA

Forza di spinta (F) / *tangential force (F)*
max 1130 N

Mezzeria pastiglia (Mp) / *pad center (Mp)*
0,032 m

Peso / *Weight*
5,4 kg

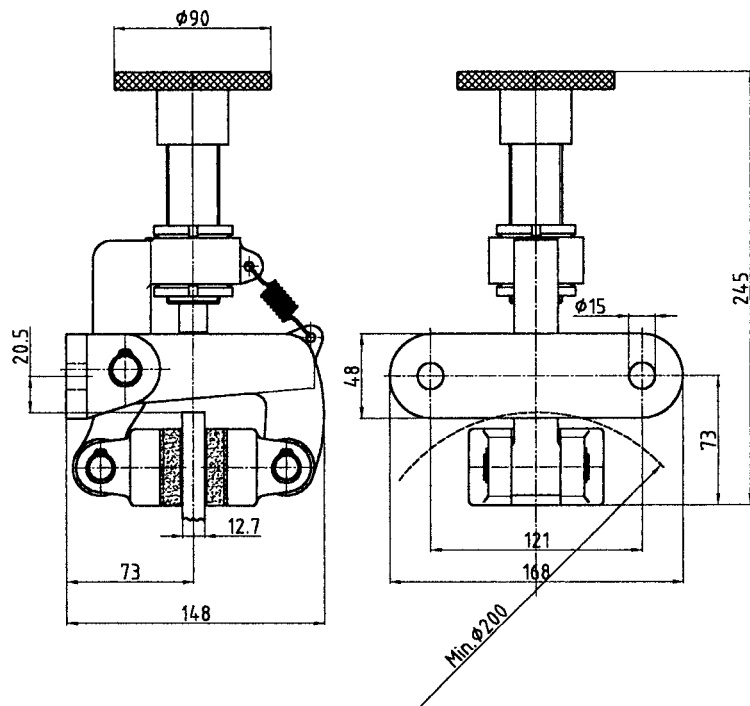
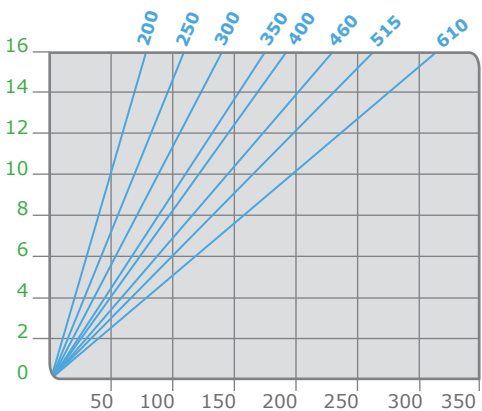

■ Diametro del disco mm / *Disc diameter mm*

■ Numero giri del volantino / *Number of handwheel turns*

■ Coppia frenante Nm / *Braking torque Nm*

PINZE PNEUMATICHE POSITIVE PNEUMATIC CALIPER BRAKES AIR APPLIED

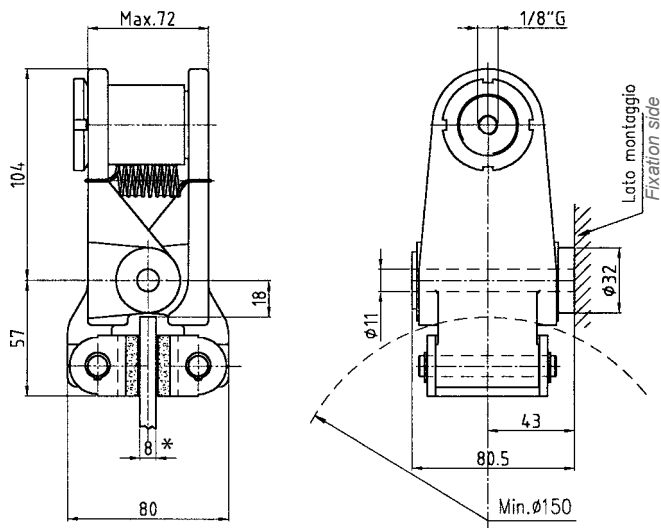

*12,7 su richiesta / if required

PU/P-SA

Forza di spinta (F) / tangential force (F)
560 N a 7 bar / 560 N at 7 bar

Mezzeria past. (Mp) / pad center (Mp)
0,025 m

Pressione massima / Max pressure
7 bar

Volume aria / Air volume
0,002 dm³

Peso / Weight
2,3 kg

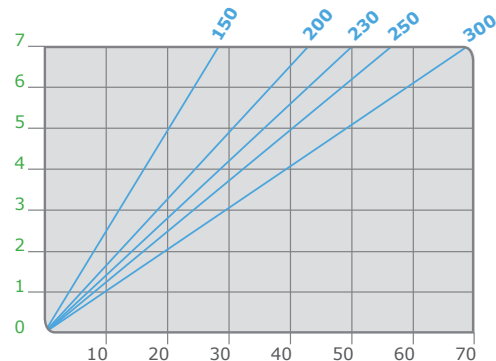

PU 2"-SA

Forza di spinta (F) / tangential force (F)
1579 N a 7 bar / 1579 N at 7 bar

Mezzeria past. (Mp) / pad center (Mp)
0,025 m

Pressione massima / Max pressure
7 bar

Volume aria / Air volume
0,007 dm³

Peso / Weight
3,1 kg

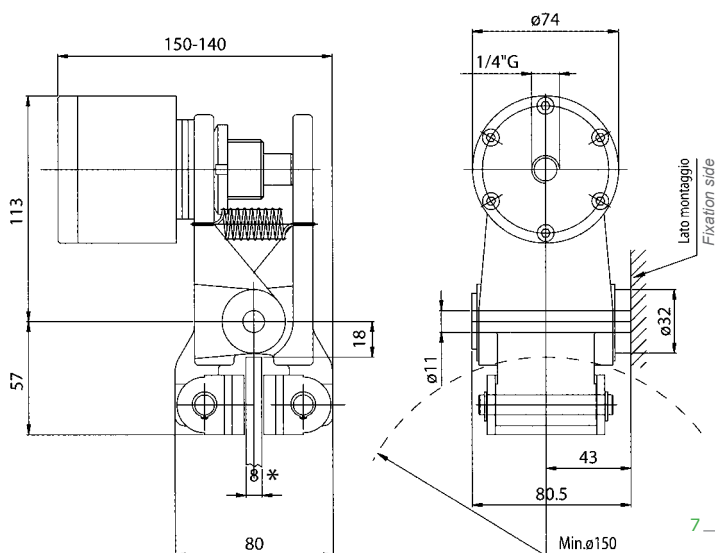

*12,7 su richiesta / if required

■ Diametro del disco mm / Disc diameter mm

■ Pressione alimentazione kg/cm³ / Air pressure kg/cm³

■ Coppia frenante Nm in fase di slittamento continuo
Braking torque Nm / in tensioning

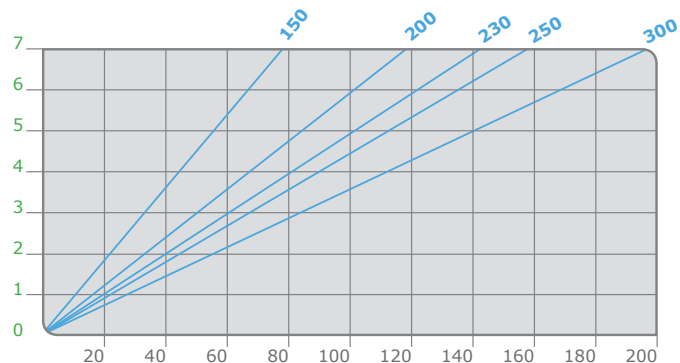

PINZE PNEUMATICHE POSITIVE PNEUMATIC CALIPER BRAKES AIR APPLIED

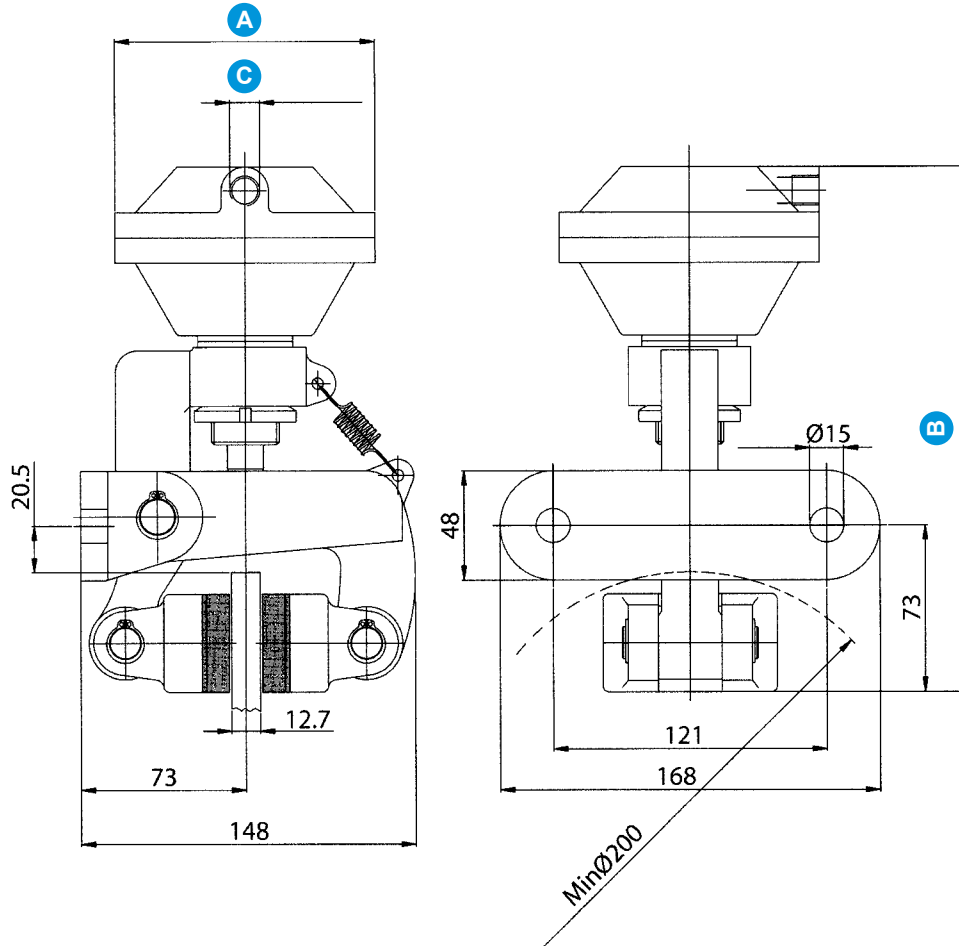

PZ-2"-SA PZ-3"-SA PZ-4"-SA

Mezzeria pastiglia (Mp)
Pad center (Mp)
0,032 m

■ Diametro del disco mm
Disc diameter mm

■ Pressione alimentazione kg/cm³
Air pressure kg/cm³

■ Coppia frenante Nm
in fase di slittamento continuo
Braking torque Nm
in tensioning

PZ-2"-SA

PZ-3"-SA

PZ-4"-SA

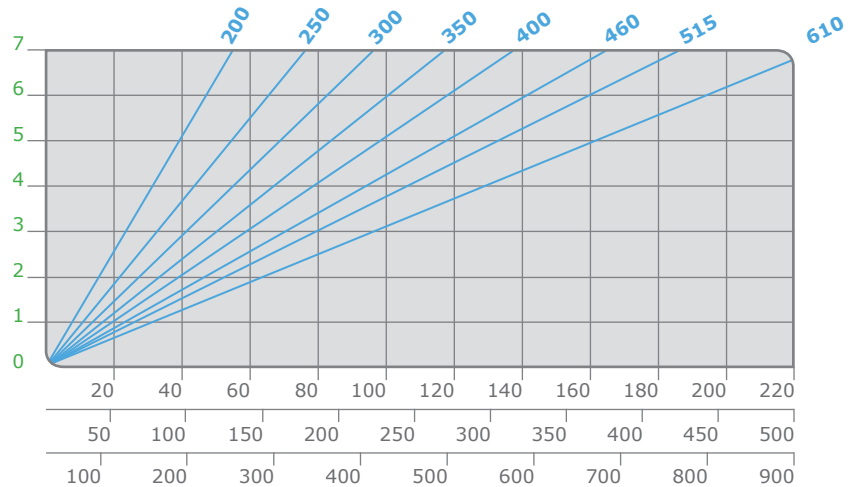

Modello Model	Misure / Measure			Peso Weight	Volume aria Air volume	Forza di spinta (F) Tangential force (F)	Pressione max Max pressure
	Ø A	B	C				
PZ-2"-SA	74	211	1/4" G	2,5 kg	0,007 dm ³	816 N a 7 bar	7 bar
PZ-3"-SA	115	225	1/4" G	6,2 kg	0,12 dm ³	1866 N a 7 bar	7 bar
PZ-4"-SA	140	236,5	3/8" G	7,5 kg	0,25 dm ³	3500 N a 7 bar	7 bar

PINZE PNEUMATICHE POSITIVE PNEUMATIC CALIPER BRAKES AIR APPLIED

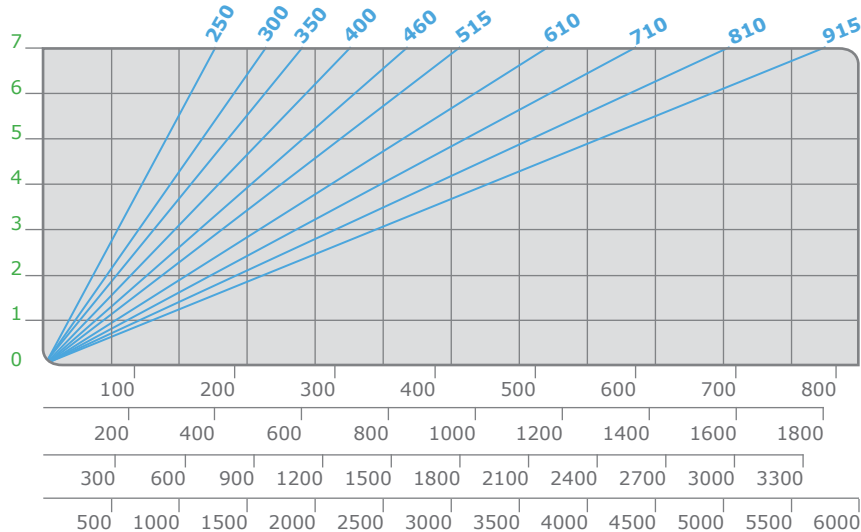
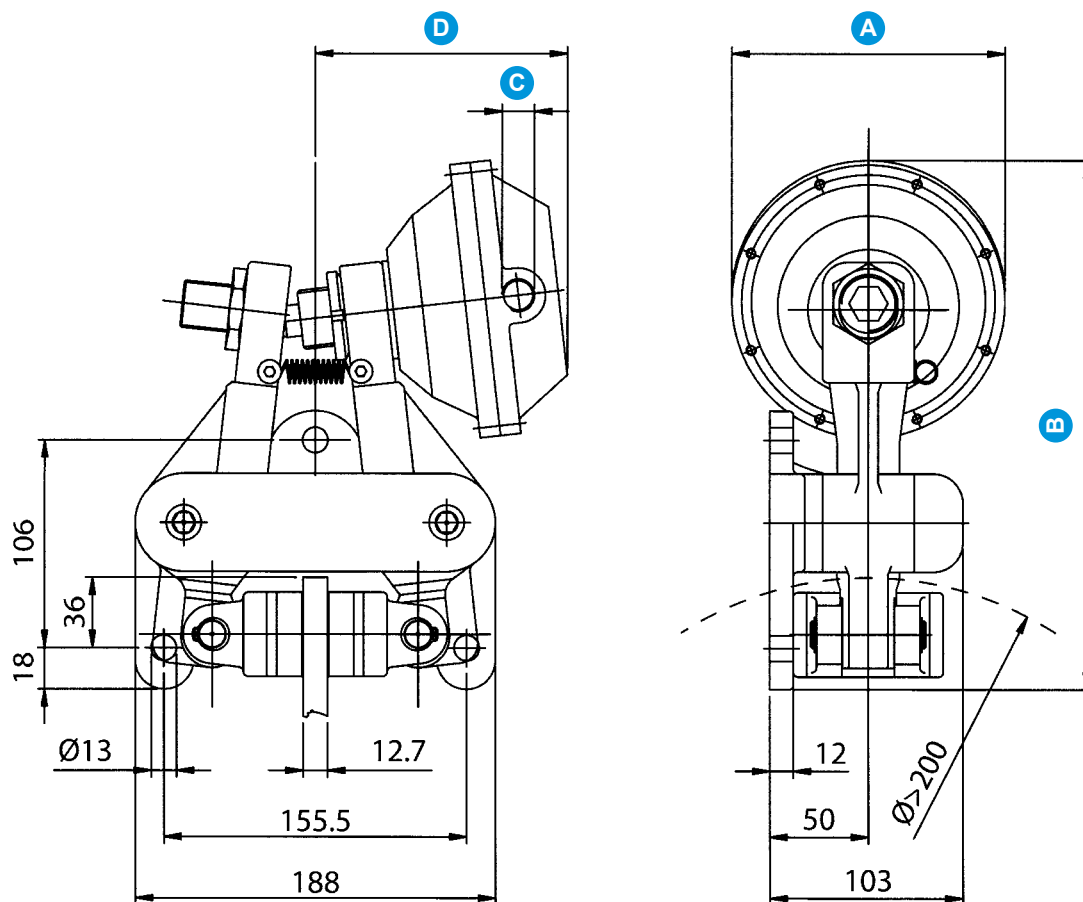

PZM12-2"-SA
PZM12-3"-SA
PZM12-4"-SA
PZM12-5"-SA

Mezzeria pastiglia (Mp)
Pad center (Mp)
0,03 m

PZM12-2"-SA

PZM12-3"-SA

PZM12-4"-SA

PZM12-5"-SA

Modello Model	Ø A	B	C	D	Peso Weight	Volume aria Air volume	Forza di spinta (F) Tangential force (F)	Pressione max Max pressure
PZM12-2"-SA	74	237	1/4" G	108	8,9 kg	0,007 dm ³	1843 N a 7 bar	7 bar
PZM12-3"-SA	115	257	1/4" G	122	10,2 kg	0,12 dm ³	4232 N a 7 bar	7 bar
PZM12-4"-SA	140	273	3/8" G	135	11,3 kg	0,25 dm ³	8050 N a 7 bar	7 bar
PZM12-5"-SA	185	295	3/8" G	165	15 kg	0,4 dm ³	13416 N a 7 bar	7 bar

PINZE PNEUMATICHE POSITIVE PNEUMATIC CALIPER BRAKES AIR APPLIED

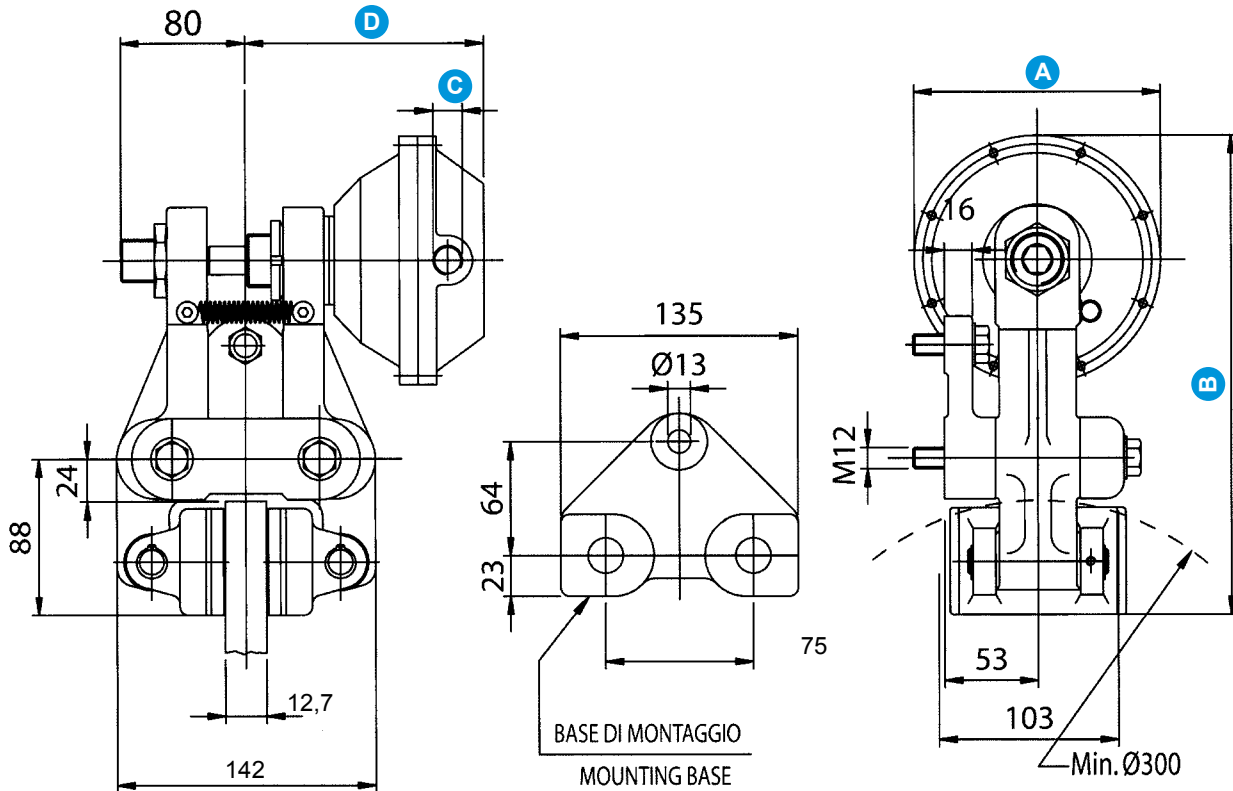

PZR-2"-SA PZR-3"-SA PZR-4"-SA PZR-5"-SA

Mezzeria pastiglia (Mp)
Pad center (Mp)
0,033 m

Diametro del disco mm
Disc diameter mm

Pressione alimentazione kg/cm³
Air pressure kg/cm³

Coppia frenante Nm
in fase di slittamento continuo
Braking torque Nm
in tensioning

PZR-2"-SA

PZR-3"-SA

PZR-4"-SA

PZR-5"-SA

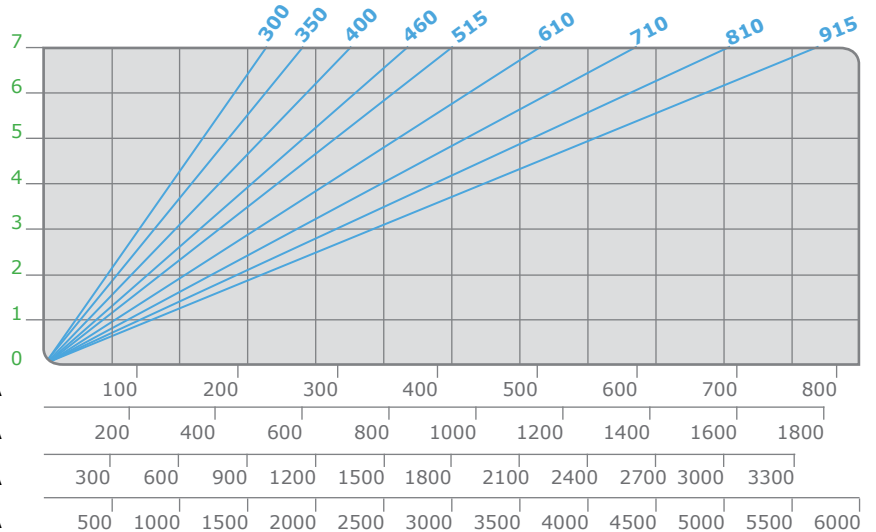

Modello Model	Ø A	B	C	D	Peso Weight	Volume aria Air volume	Forza di spinta (F) Tangential force (F)	Pressione max Max pressure
PZR-2"-SA	74	241	1/4" G	107	9,3 kg	0,007 dm ³	1843 N a 7 bar	7 bar
PZR-3"-SA	115	258	1/4" G	135	10,6 kg	0,12 dm ³	4232 N a 7 bar	7 bar
PZR-4"-SA	140	270	3/8" G	135	11,7 kg	0,25 dm ³	8050 N a 7 bar	7 bar
PZR-5"-SA	185	293	3/8" G	155	15,4 kg	0,4 dm ³	13416 N a 7 bar	7 bar

PINZE PNEUMATICHE POSITIVE PNEUMATIC CALIPER BRAKES AIR APPLIED

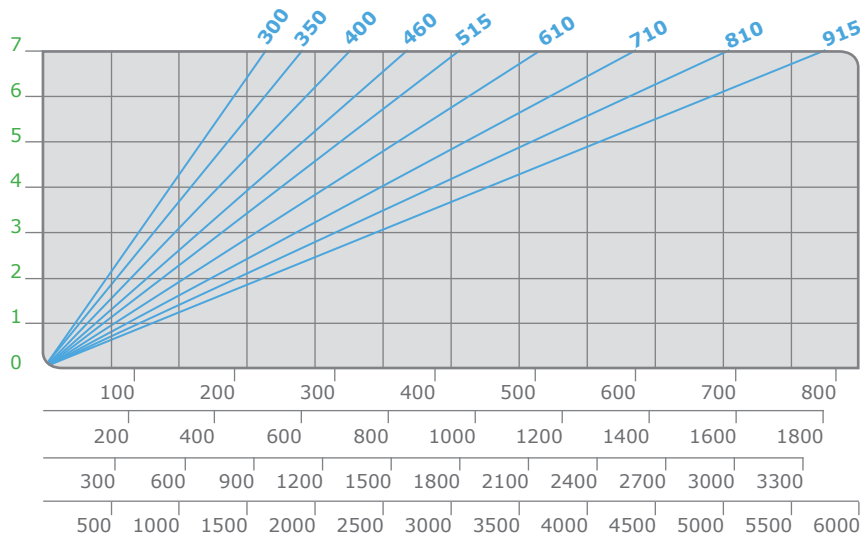
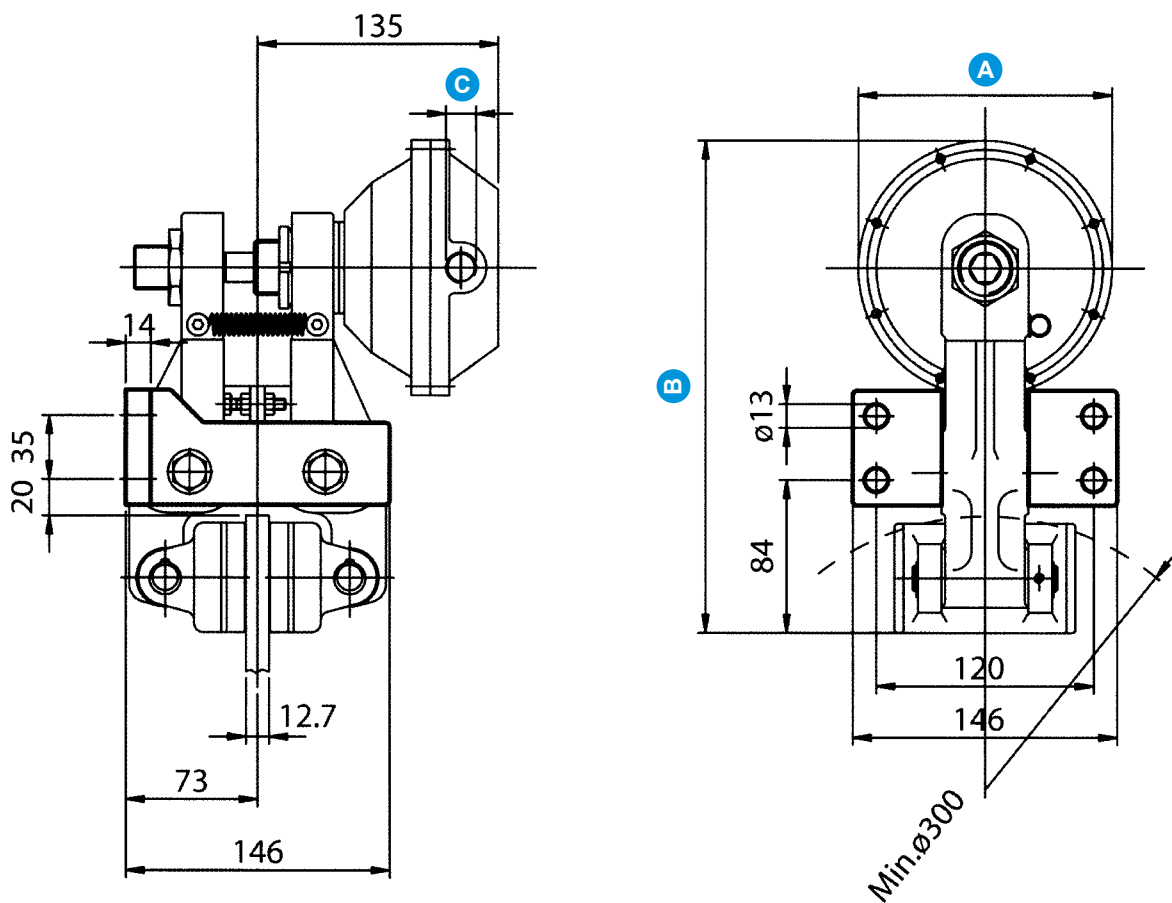

PZD-2''-SA
PZD-3''-SA
PZD-4''-SA
PZD-5''-SA

Mezzeria pastiglia (Mp)
Pad center (Mp)
0,033 m

PZD-2''-SA
PZD-3''-SA
PZD-4''-SA
PZD-5''-SA

Modello Model	Ø A	B	C	Peso Weight	Volume aria Air volume	Forza di spinta (F) Tangential force (F)	Pressione max Max pressure
PZD-2''-SA	74	241	1/4" G	9,4 kg	0,007 dm ³	1843 N a 7 bar	7 bar
PZD-3''-SA	115	258	1/4" G	10,7 kg	0,12 dm ³	4232 N a 7 bar	7 bar
PZD-4''-SA	140	270	3/8" G	11,8 kg	0,25 dm ³	8050 N a 7 bar	7 bar
PZD-5''-SA	185	293	3/8" G	15,5 kg	0,4 dm ³	13416 N a 7 bar	7 bar

PINZE PNEUMATICHE POSITIVE PNEUMATIC CALIPER BRAKES AIR APPLIED

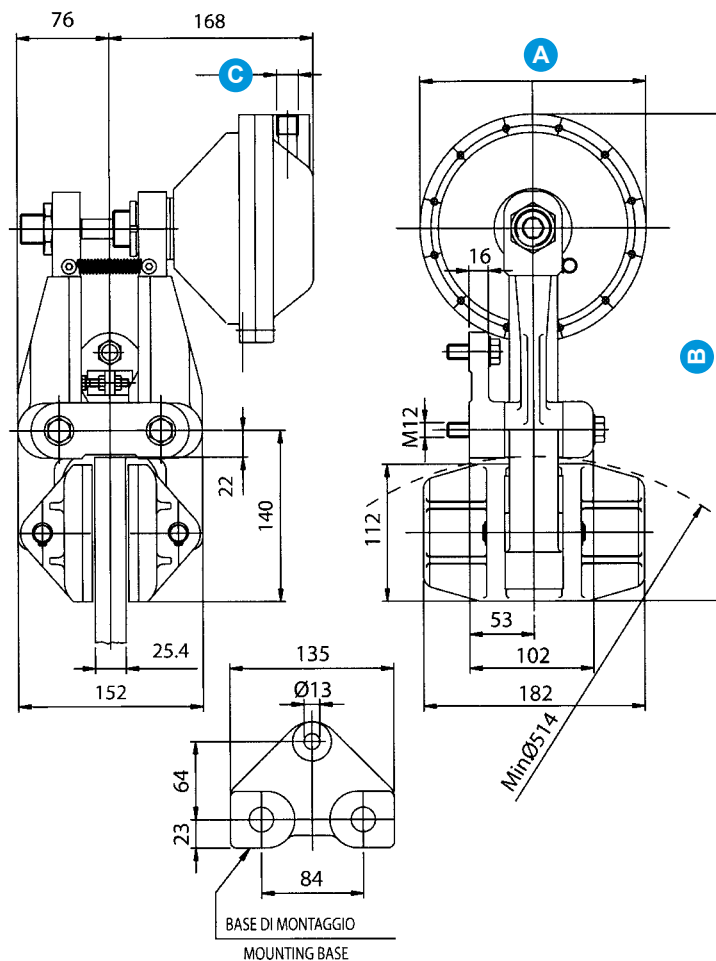

PZL-3"-SA PZL-4"-SA PZL-5"-SA PZL-6"-SA

Mezzeria pastiglia (Mp)
Pad center (Mp)
0,062 m

■ Diametro del disco mm
Disc diameter mm

■ Pressione alimentazione kg/cm³
Air pressure kg/cm³

■ Coppia frenante Nm
in fase di slittamento continuo
Braking torque Nm
in tensioning

PZL-3"-SA

PZL-4"-SA

PZL-5"-SA

PZL-6"-SA

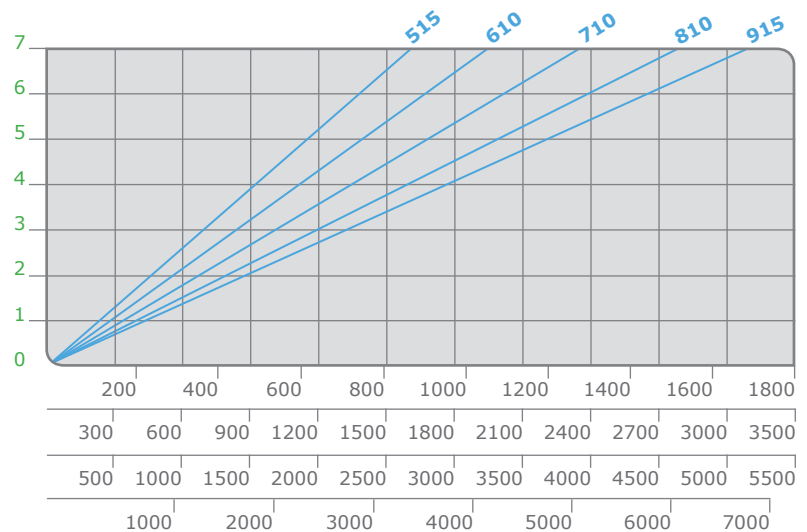

Modello Model	Ø A	B	C	Peso Weight	Volume aria Air volume	Forza di spinta(F) Tangential force (F)	Pressione max Max pressure
PZL-3"-SA	115	362,5	1/4" G	16,2 kg	0,12 dm ³	4232 N a 7 bar	7 bar
PZL-4"-SA	140	375	3/8" G	17,3 kg	0,25 dm ³	8050 N a 7 bar	7 bar
PZL-5"-SA	185	398	3/8" G	21 kg	0,4 dm ³	13416 N a 7 bar	7 bar
PZL-6"-SA	216	413	1/2" G	19,5 kg	0,4 dm ³	17400 N a 7 bar	7 bar

PINZE PNEUMATICHE POSITIVE PNEUMATIC CALIPER BRAKES AIR APPLIED

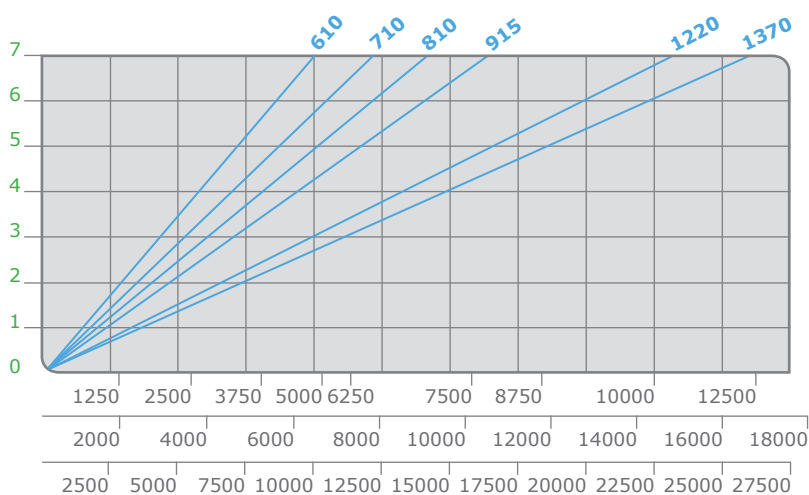
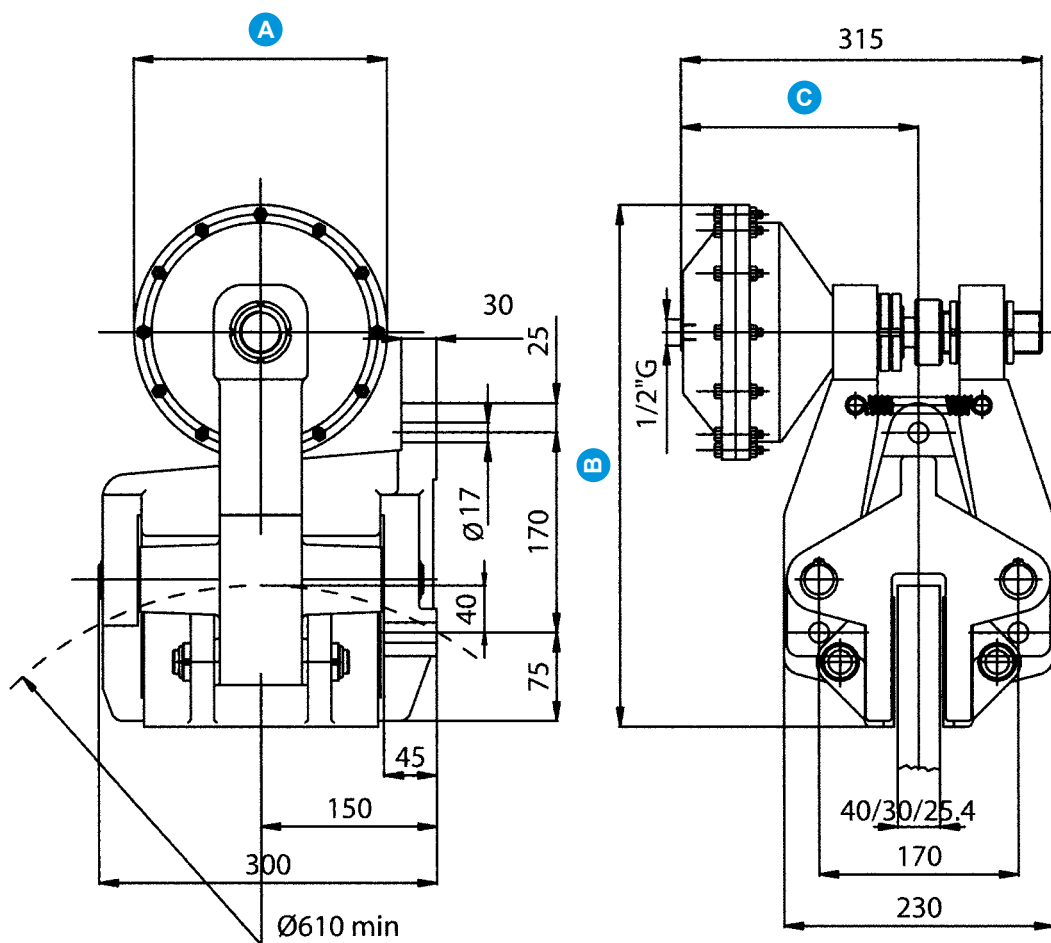

PR-5"-25-SA
PR-6"-25-SA
PR-7"-25-SA

Mezzeria pastiglia (Mp)
Pad center (Mp)
0,065 m

PR-5"-25-SA

PR-6"-25-SA

PR-7"-25-SA

Modello Model	Ø A	B	C	Peso Weight	Volume aria Air volume	Forza di spinta (F) Tangential force (F)	Pressione max Max pressure
PR-5"-25-SA	185	428	195 mm	50 kg	0,4 dm ³	20000 N a 7 bar	7 bar
PR-6"-25-SA	216	443	210 mm	48 kg	0,8 dm ³	27000 N a 7 bar	7 bar
PR-7"-25-SA	258	465	220 mm	59 kg	1 dm ³	42000 N a 7 bar	7 bar

PINZE PNEUMATICHE NEGATIVE tipo CX, SA

La nostra gamma comprende modelli ad azionamento manuale o pneumatico da utilizzare in abbinamento ai nostri dischi PX. I dischi sono disponibili in ghisa da 200 a 600 mm, ma possono essere realizzati in conformità alle esigenze del cliente.

I modelli in versione negativa sono azionati tramite molle precaricate e consentono di effettuare la frenatura di sicurezza.

PNEUMATIC CALIPER BRAKES SPRING APPLIED, CX, SA series

Our product range includes manually operated and pneumatic calipers, both to be used with our PX discs. The discs are available in cast iron from 200 to 600 mm but they can also be manufactured according to the customer's special requirements.

The spring applied caliper brakes are driven by a pre-charged spring and are therefore ideal for the security braking.



PINZA PNEUMATICA CX negativa CX PNEUMATIC CALIPER BRAKE spring applied

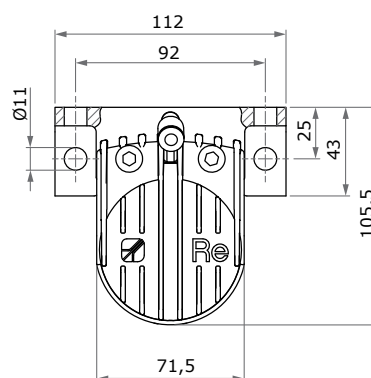
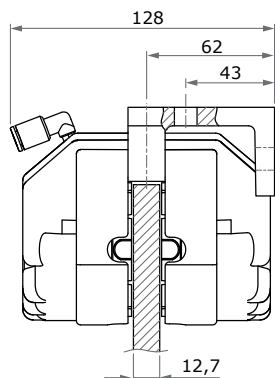

pinza CX negativa 4,5 bar
CX caliper spring applied 4,5 bar

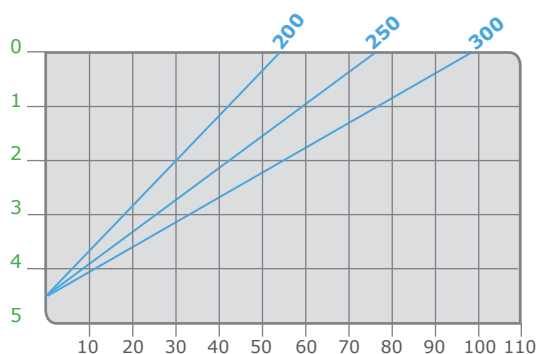

F= 855 N forza di spinta a 4,5 bar / *tangential force at 4,5 bar*

pinza CX negativa 6 bar
CX caliper spring applied 6 bar

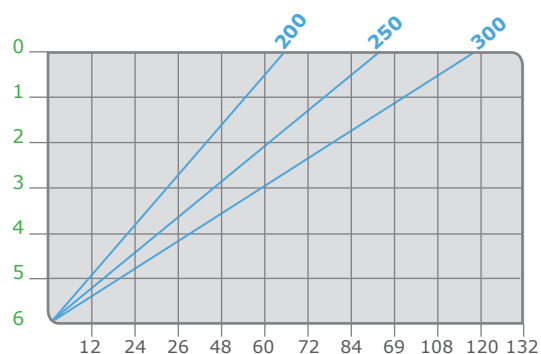

F= 1000 N forza di spinta a 6 bar / *tangential force at 6 bar*

- Diametro del disco mm / *Disc diameter mm*
- Pressione alimentazione kg/cm³ / *Air pressure kg/cm³*
- Coppia frenante Nm in fase di slittamento continuo / *Braking torque Nm / in tensioning*

Mezzeria pastiglia (Mp) / *pad center (Mp)*
0,065 m

PINZE PNEUMATICHE NEGATIVE PNEUMATIC CALIPER BRAKES SPRING APPLIED

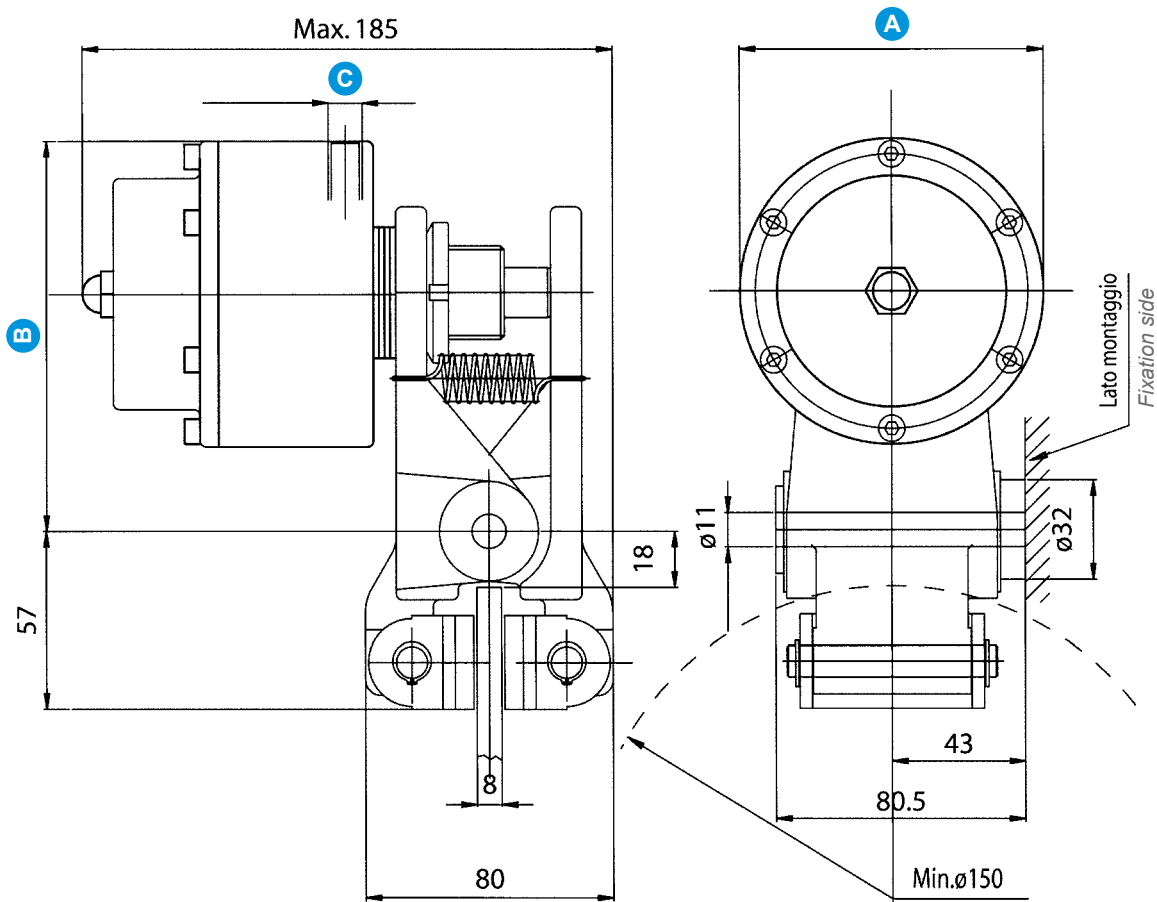

PU-2"N-SA PU-3"N-SA

Mezzeria pastiglia (Mp)
Pad center (Mp)
0,025 m

■ Diametro del disco mm
Disc diameter mm

■ Pressione alimentazione kg/cm³
Air pressure kg/cm³

■ Coppia frenante Nm
in fase di slittamento continuo
Braking torque Nm
in tensioning

PU-2"N-SA
PU-3"N-SA

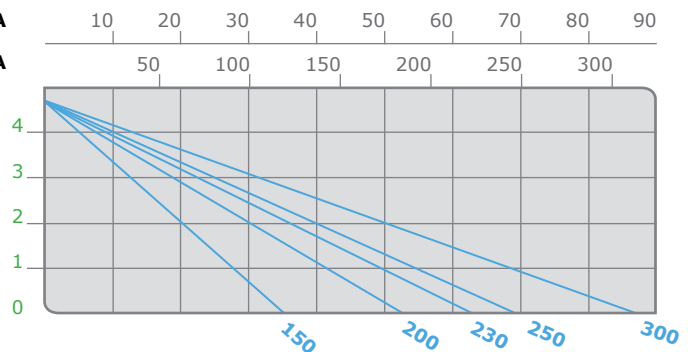

Modello Model	∅ A	B	C	Peso Weight	Volume aria Air volume	Forza di spinta (F) Tangential force (F)	Pressione min apert. Least pressure open.
PU-2"N-SA	60	106	1/4" G	3,2 kg	0,04 dm ³	max 690 N	5 bar
PU-3"N-SA	98	125	1/4" G	4 kg	0,07 dm ³	max 2550 N	5 bar

PINZE PNEUMATICHE NEGATIVE PNEUMATIC CALIPER BRAKES SPRING APPLIED

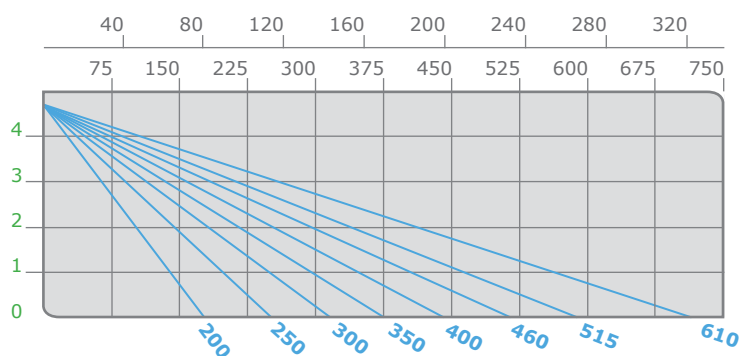
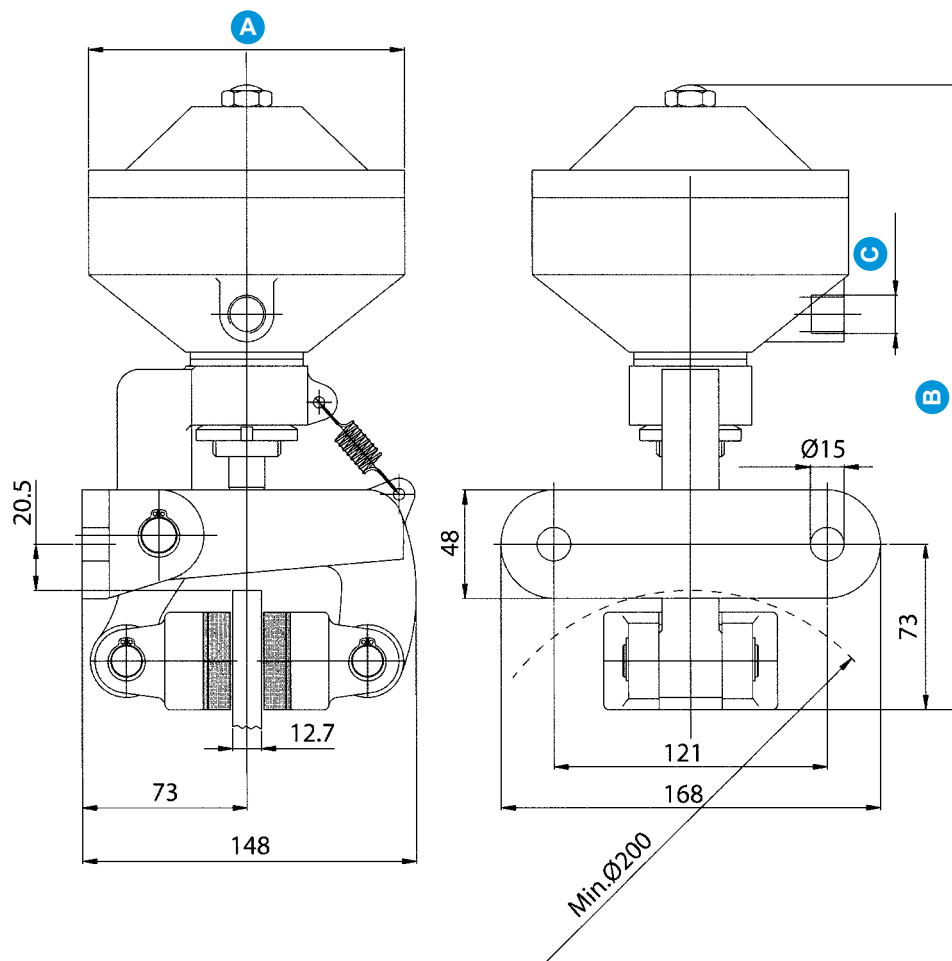

PZ-3''N-SA

PZ-4''N-SA

PZ-3''N-SA
PZ-4''N-SA

Mezzeria pastiglia (Mp)
Pad center (Mp)
0,032 m

Modello Model	Ø A	B	C	Peso Weight	Volume aria Air volume	Forza di spinta (F) Tangential force (F)	Pressione min apert. Least pressure open.
PZ-3''N-SA	98	253	1/4" G	6 kg	0,07 dm ³	max 1200 N	5 bar
PZ-4''N-SA	140	275	3/8" G	9,2 kg	0,3 dm ³	max 2600 N	5 bar

PINZE PNEUMATICHE NEGATIVE PNEUMATIC CALIPER BRAKES SPRING APPLIED

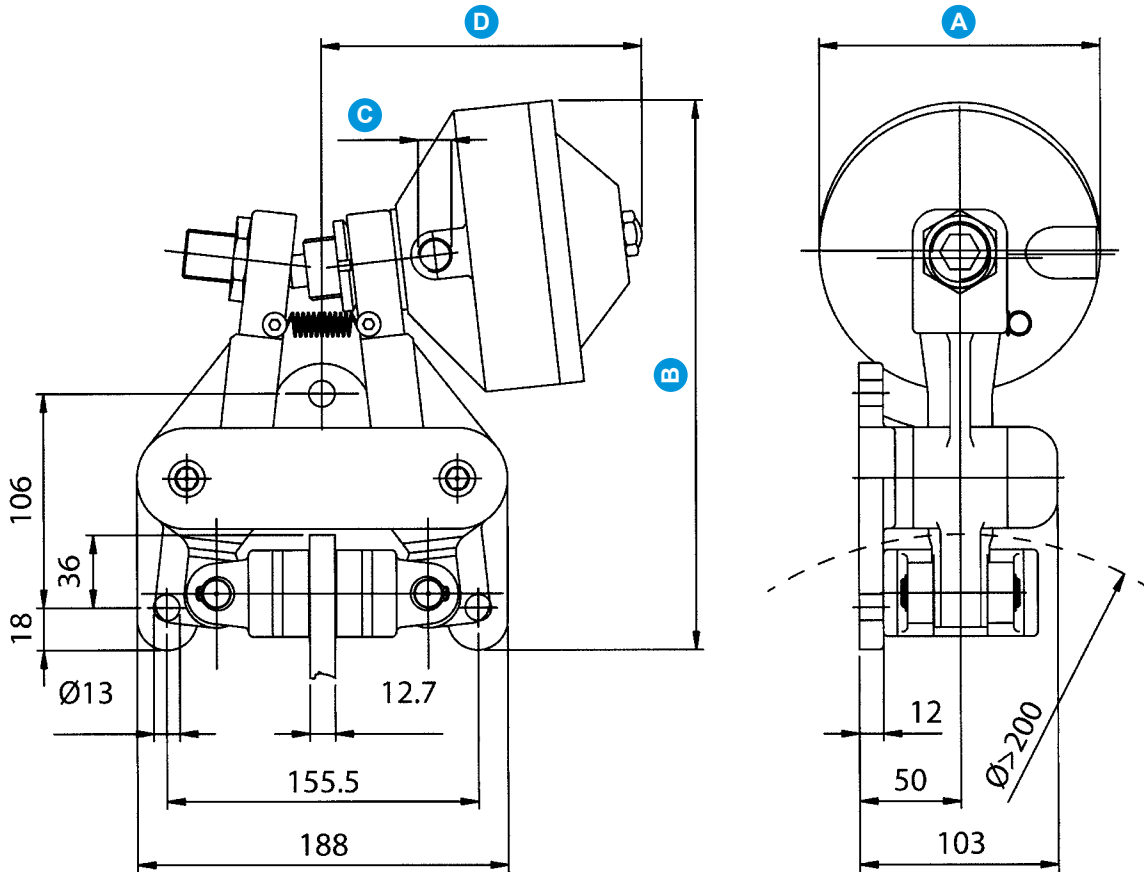

PZM12-3"N-SA PZM12-4"N-SA PZM12-5"N-SA

Mezzeria pastiglia (Mp)
Pad center (Mp)
0,03 m

■ Diametro del disco mm
Disc diameter mm

■ Pressione alimentazione kg/cm³
Air pressure kg/cm³

■ Coppia frenante Nm
in fase di slittamento continuo
Braking torque Nm
in tensioning

PZM12-3"N-SA	100	200	300	400	500	600	700	800	900	1000	1100	1200
PZM12-4"N-SA	250	500	750	1000	1250	1500	1750	2000	2250	2500	2750	
PZM12-5"N-SA	500	1000	1500	2000	2500	3000	3500	4000	4500	5000		

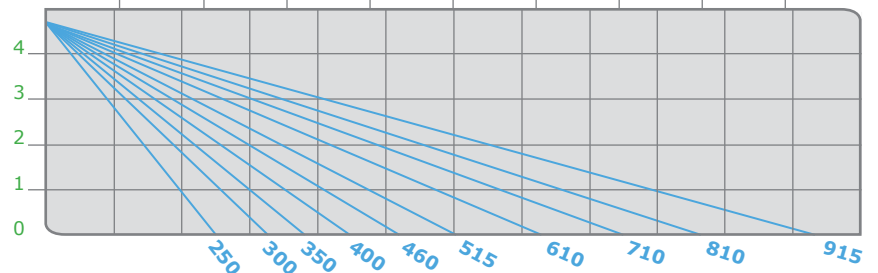

Modello Model	Ø A	B	C	D	Peso Weight	Volume aria Air volume	Forza di spinta (F) Tangential force (F)	Pressione min apert. Least pressure open.
PZM12-3"N-SA	98	251	1/4" G	145	9,75 kg	0,07 dm ³	2600 N	5 bar
PZM12-4"N-SA	140	272	3/8" G	170	13,6 kg	0,3 dm ³	max 5900 N	5 bar
PZM12-5"N-SA	185	296	3/8" G	200	18,3 kg	0,7 dm ³	max 11000 N	5 bar

PINZE PNEUMATICHE NEGATIVE PNEUMATIC CALIPER BRAKES SPRING APPLIED

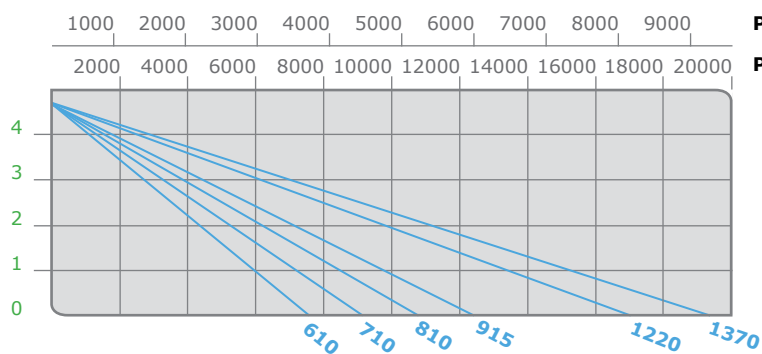
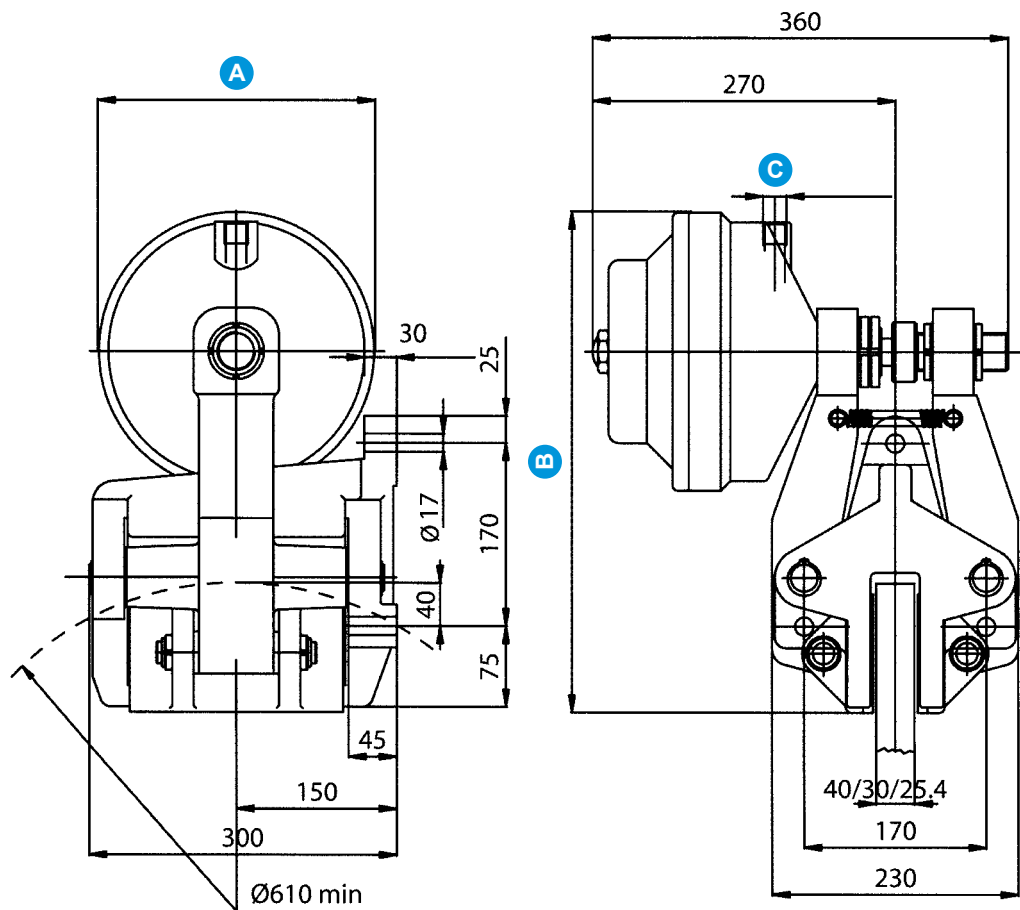

PR-5"N-25-SA

PR-7"N-25-SA

PR-5"N-25-SA
PR-7"N-25-SA

Mezzeria pastiglia (Mp)
Pad center (Mp)
0,065 m

Modello Model	Ø A	B	C	Peso Weight	Volume aria Air volume	Forza di spinta (F) Tangential force (F)	Pressione min apert. Least pressure open.
PR-5"N-25-SA	185	428	3/8" G	53 kg	0,7 dm ³	14800 N	5 bar
PR-7"N-25-SA	258	465	1/2" G	67 kg	3 dm ³	max 31180 N	5 bar

DISCHI DISCS

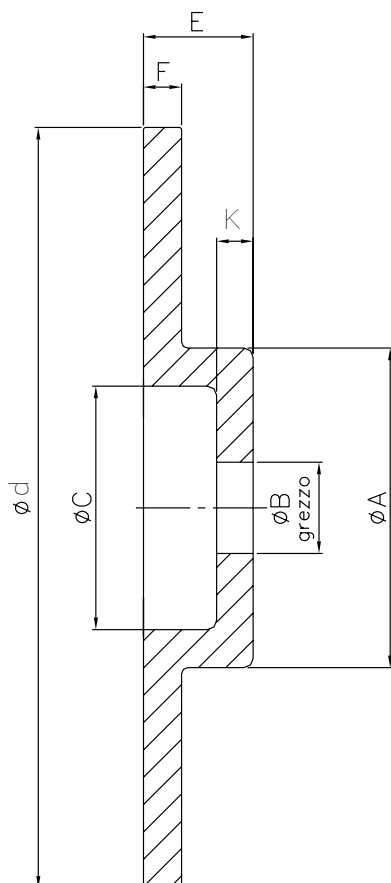

Per il calcolo della coppia dinamica (C_d) di una pinza CX utilizzare la seguente formula:

$$C_d = R_m \cdot F$$

F = forza tangenziale della pinza sulla superficie del disco comprensivo dell'attrito della pastiglia

$$R_m = \frac{d - M_p}{2}$$

R_m = raggio medio [m]

d = diametro del disco [m]

M_p = mezzeria pastiglia [m]*

* misura variabile in base alle dimensioni della pinza prescelta (vedere la relativa pagina)

To calculate the dynamic torque (C_d) of the CX caliper use the following formula:

$$C_d = R_m \cdot F$$

F = thrust force of the caliper on the disc's surface including the attrition of the pad

$$R_m = \frac{d - M_p}{2}$$

R_m = medium radius

d = diameter of the discs

M_p = mezzeria pastiglia*

*variable dimension related to the selected caliper size (see at the related page)

Modello Model	Dimensioni Dimensions							Inerzia Inertia Kgm ²	Peso Weight Kg	Giri/1' RPM n°
	Ød	A	B	C	K	E	F			
PX-PZ	250	105	20	80	12	36	12,7	0,04	4	2700
PZ	250	128	20	118	6	36	12,7	0,04	4,1	2700
PX-PZ	300	150	30	130	13	41	12,7	0,09	7	2300
PZ	300	181	30	163	13	41	12,7	0,09	7,4	2300
PX-PZ	356	210	40	173	16	54	12,7	0,2	12	2100
PX-PZ	406	260	44	236	16	54	12,7	0,32	14	1700
PX-PZ	457	311	44	276	16	54	12,7	0,6	20	1500
PX-PZ	514	368	44	340	16	54	12,7	0,7	24	1300
PX-PZ	610	464	44	430	16	54	12,7	1,81	35	1100
PX-PZ	711	565	80	528	16	54	12,7	3,4	55	900





Controlli Industriali

Re S.p.A.
Via Firenze 3 | 20060 Bussero (MI) Italy
T +39 02 9524301 F +39 02 95038986
E info@re-spa.com



made in Italy

CALIPERS-I-GB-05/08 - rev. 12/15

www.re-spa.com

